

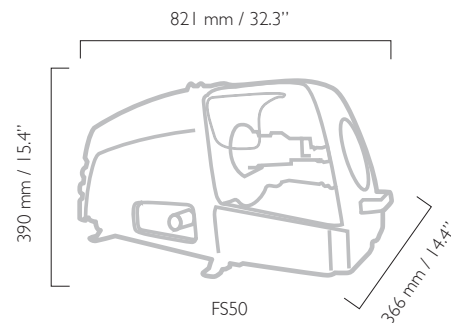

FS50



FINN-POWER FS50 SKIVING MACHINE FOR
QUALITY RESULTS

FS50 – EFFICIENT HOSE SKIVING

Finn-Power FS50 is a skiving machine that prepares hydraulic hoses for high demanding crimping. The machine is ergonomically designed for efficiency and ease of use. FS50 has adjustable tool operation, which saves in tool costs, and maximizes productivity.



www.lillbackausa.com

Description	Pno	Size
Internal mandrels	707187	1/2"
	707182	5/8"
	707167	3/4"
	707166	1"
	707179	1 1/4"
	707181	1 1/2"
	707184	2"
External mandrels	707660	3/16"
	707658	1/4"
	707657	5/16"
	707656	3/8"
	707038	1/2"
	707040	5/8"
	707042	3/4"
	707041	1"
	707070	1 1/4"
	707168	1 1/2"
707169	2"	
Tool rack	707253	

FS50	
Hose capacity, external inch	3 / 16"-2"
Hose capacity, internal inch	1/2"-2"
Motor (kW)	0,75
Motor (HP)	1
Speed of tool rotation, r / min	100
Weight (kg)	34
Weight (lbs)	75